

### FT 046.0500.25

cable winder with powder coated sheet steel plates, 2-fold ball beared, spring catch as hose locking device, without cable, with slip rings 25A (4-pole + PE)

Order-No.	Weight
631 32 500	24.30 kg 53.60 lb

#### Measures in mm/inch

<b>A:</b> 460 / 18,11	<b>G:</b> 247 / 9,72	3,94
<b>B:</b> 320 / 12,6	<b>H:</b> 130 / 5,12	<b>N:</b> 80 / 3,15
<b>C:</b> 543 / 21,38	<b>J:</b> 320 / 12,6	<b>O:</b> 10 / 0,39
<b>D:</b> 150 / 5,91	<b>K:</b> 50 / 1,97	<b>P:</b> 212 /
<b>E:</b> 120 / 4,72	<b>L:</b> 143 / 5,63	8,35
<b>F:</b> 8 / 0,31	<b>M:</b> 100 /	

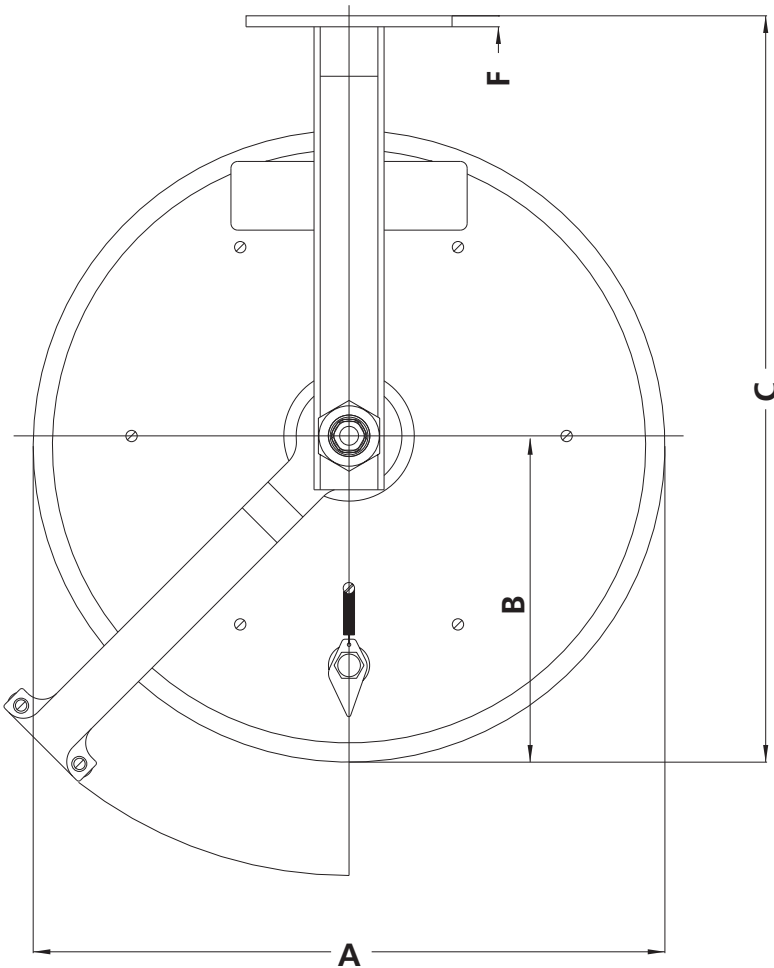
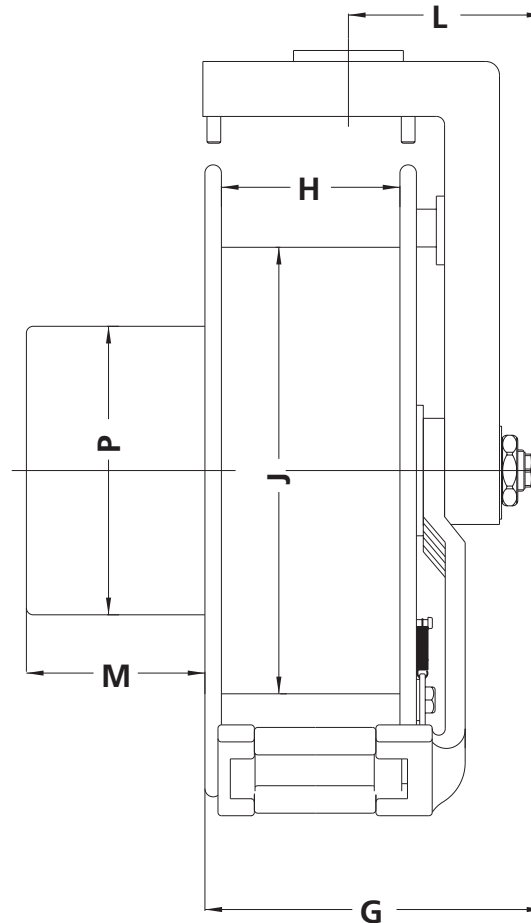

**Schill GmbH & Co. KG**  
Bruckstr. 44  
70734 Fellbach/Germany

Phone: +49 (0) 711 57 88 07-0  
Fax: +49 (0) 711 57 88 07-44  
info@schill.de  
www.schill.de